

QUARTZ-LOCKED PLL DIRECT DRIVE RECORD PLAYER

# DQX-500



## Features

- 350mm diameter platter with 600 kg·cm<sup>2</sup> moment of inertia and quartz lock servo PLL DC motor

The platter used for the DQX-500 features an extremely high moment of inertia of 600 kg·cm<sup>2</sup>, and this helps suppress fluctuations in the pulsive mechanical amplitude caused by the sound grooves on the record. As far as the static characteristics are concerned, the quartz lock servo system guarantees an outstanding constant speed stability. However, it cannot be said to control perfectly the random transient load generated by the reproduction of the record sound. In particular, turntables rely for the most part on their platter's moment of inertia to deal with disturbances in the high frequency range components for an overall improvement in the characteristics. Therefore, based on the basic servo control system, the static load fluctuations are absorbed by the quartz lock PLL system, and the dynamic load fluctuations are improved by the moment of inertia.

- Stand-by lamp for easy rated speed checks

The quartz lock servo PLL system provides a rotational speed with no deviation from the rated 33-1/3 rpm and 45 rpm speeds. There is no need for a strobe and so this has been abandoned in favor of a simple design. When the platter with its high moment of inertia reaches the rated speed the stand-by lamp goes off. This action allows you to check whether or not the platter is revolving at the right speed.

- Resonance-free monocoque frame

The phonomotor and tonearm feature a sturdy integrated construction together with the metal frame composed of a three-legged configuration. This means that the turntable functions as a mechanical circulation system so that it is hardly affected at all by external vibration.

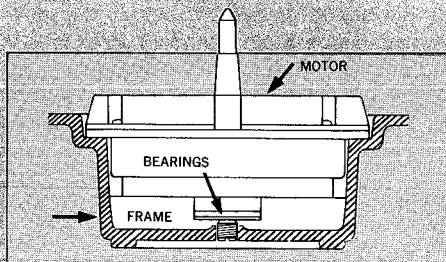

MICRO'S engineers got down to the bottom of the resonance modes caused by the conventional box-shaped construction and came up with a crystal-clear reproduced sound. This is a design which is compact, achieves an excellent weight balance and features absolutely no dead space. The motor shaft bearings are coupled to the frame with the reinforcement and there is plenty of mechanical strength to support the high inertia which accompanies the rotation of this heavyweight platter. All these features make for an extremely distinct sound image.

- Outer power transformer power supply for an improvement in the signal-to-noise ratio

In order to handle the very faint signals which are transmitted through the cartridge turntables have been beset with the problem of induction-caused noise from the AC power source. If you use a moving coil (MC) cartridge, the flux generated by a power transformer, for instance can sometimes be the cause of hum. This is why the DQX-500 features a separate power transformer. It is designed to accommodate all the controls. You can therefore use the transformer as far away from the cartridge and tonearm as possible.

# MICRO SEIKI

## HIGH FIDELITY TURNTABLE SYSTEMS

■ **Low mass type dynamic balance tonearm MA-707**

The MA-707 is a newly developed dynamic balance tonearm featuring superb tracking due to the light stylus force. And the low effective mass perfectly matches the characteristics of high-compliance type cartridges. Another feature is the rigid yet light aluminum alloy used in the pipe part of the arm. The internal lead wires are actually tiny coaxial cables. Hard gold plating of the headshell terminals and plug-in type construction assure perfect conductivity. The unique dynamic balance system has been made practical due to the spring system (patent pending) using a torsion bar. Linearity is outstanding even with extremely light stylus force.

Even with low-compliance type cartridges, the correct balance can be obtained by adding weights to compensate.

■ **A complete solution to the problems of the dynamic balance system**

There are few dynamic balance type tonearms in the market even though this type is said to be ideal. One reason is the precision required for the spring built into the dynamic balance system. The weak points are the difficulty of maintaining spring linearity at light stylus forces and loss of tension with the passage of time. The MA-707 uses a precision spring developed through strict selection of materials and high precision processing. These problems have been completely solved by the use of a torsion bar. Stylus force change is extremely linear from 0.3 to 3.0 grams, by 0.1 gram step. Tracing is extremely sensitive at low stylus forces, with high compliance type cartridges.

● **A dynamic balance system without inertial moment**

The tonearm itself is perfectly balanced and stylus force is applied only through the tension of the spring. Because of this, there is no moment acting upward due to unevenness of the record surface as with the static balance type. In other words, whatever the condition of the record surface, the stylus force is constant. And there is almost no influence from the warp of record and eccentricity the turntable being out of level, etc.

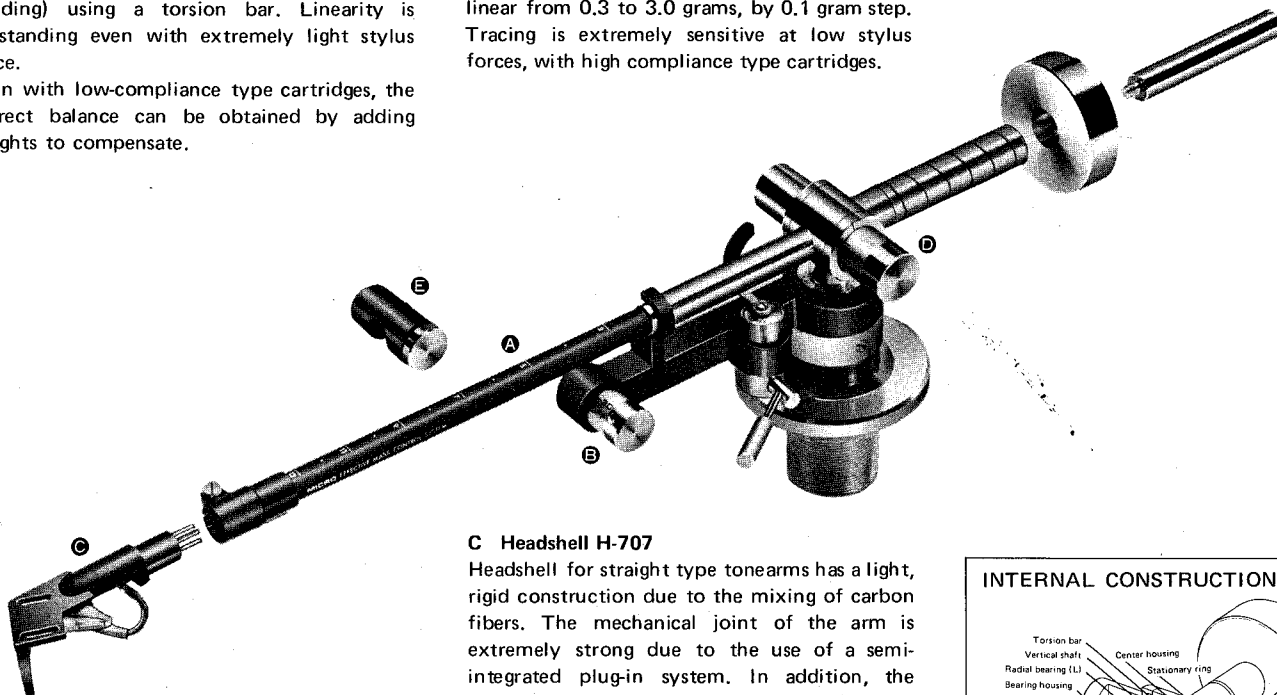

**A Positive operating straight type**

One of the features of the straight type, in which the tip of the needle and the arm fulcrum point are arranged in a straight line, is that problems arising from bend in the arm are reduced and the pipe is very strong. Special aluminum alloy is used to provide the strength and light weight required for a low-mass type. Pipe thickness is only 0.5mm. The variable moving mass system is employed, so a scale is provided on the pipe for attaching extra weights.

Tiny coaxial cable is used inside the pipe. This, plus the use of oxygen-free copper means that transmission of small signals is improved.

**B Anti-skating force devices**

This anti-skating force device is of the stylus force response type so it is possible to maintain a constant stylus force against both walls of groove at any part of the record by setting the anti-skating scale onto same figure as a stylus force. The canceller controls is installed, together with the arm rest, onto a heavy zinc stay. By combining with the brass arm shaft base, the total mass obtained results in extremely stable arm operation.

**C Headshell H-707**

Headshell for straight type tonearms has a light, rigid construction due to the mixing of carbon fibers. The mechanical joint of the arm is extremely strong due to the use of a semi-integrated plug-in system. In addition, the plug-in type 4-pin design with hard gold plating means that conductivity is superb. Conventional contact points are unnecessary. Fine coaxial leads are used for the cartridge connection. This, plus the use of oxygen free copper means that there is little electromagnetic influence (eddy current loss) against small signals and results in archiving extremely good transmitting characteristics.

**D Dynamic balance system (patent pending) using a newly developed torsion bar for linear stylus force**

In dynamic balance system's the basic stylus force is normally determined by spring tension. It is thus necessary to carefully consider the spring material, shape and operating accuracy as well as the effect of aging when commercializing a dynamic balance type tonearm. This unique torsion bar system uses the torsion of twisted fine wire to vary stylus force in 0.1g steps in the range from 0.3 to 3.0 grams.

The construction is such that the vertically rotating shaft is kept as far apart as possible and the total sensitivity of both these and the horizontally rotating shaft maintained while preventing influence from twisting due to external force while the arm is operating.

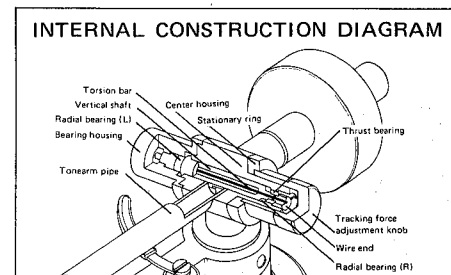

(PAT. PENDING)

**E Variable moving mass system using weights**

Basically this is a low mass type tonearm developed for use with high compliance type cartridges. But it is designed for large changes in the effective mass to obtain good balance with low-compliance type cartridges as well.

The weight is placed on the graduation mark corresponding to the guide number determined in accordance with the type of cartridge compliance, its weight, etc. Fluctuations of the moving (effective) mass determined from the cartridge compliance and weight are reflected in the resonance frequency. The resonance frequency is kept between 8-10 Hz, which is said to promote stable operation. Thus, the resonance frequency can be adjusted by moving the weight. The cartridge compliance varies for each one and there are fluctuations due to changes in the temperature; therefore, the pipe indicator must be used only as an average criterion.

**SPECIFICATIONS**

● **Motor** Drive system.....Direct drive Motor.....Quartz locked PLL DC servo motor Speeds.....33-1/3, 45rpm Turntable platter.....35cm (13-3/4 inch) diameter aluminum diecast platter, weighting 2.6kg (5.72 lbs) Moment of inertia.....600 kg·cm<sup>2</sup> Wow & flutter.....Less than 0.02% S/N ratio.....More than 63 dB (JIS) 75 dB (DIN-B) Power.....U.S.A. & Canada 120 V, 60 Hz other areas 220-240 V, 50 Hz 5 W ● **Tonearm** Type.....Dynamic balance Effective length.....237 mm (9-3/8 inch) Overhang.....15mm (19/32 inch) Maximum tracking error.....Less than 1.5° Usable cartridge weight.....4.12 g (0.14-0.42 oz) Range of tracking force adjustment.....0-3 g Dimensions.....(W) 410 x (D) 350 x (H) 139 mm, 16-1/8 x 5-1/2 inch Weight.....7.0 kg (15.4 lbs)

\* Design and specifications are subject to modification without notice.