

precision designed & engineered high fidelity record playing equipment and accessories

# MICRO

## MA-202

STATIC BALANCE TYPE TONE ARM FOR PROFESSIONAL USE

### *OPERATION MANUAL*





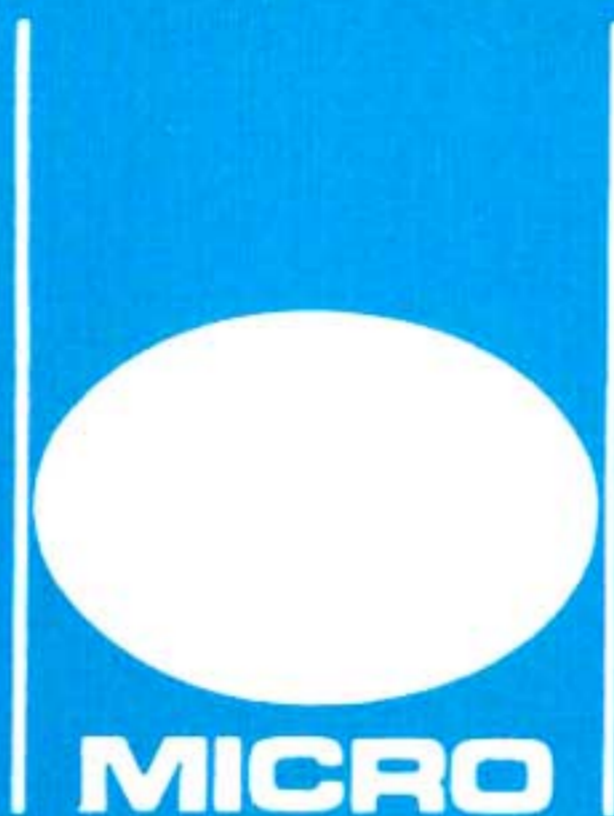

WORLD OF MICRO is created by the talented team of engineers, skilled sound technicians and expert designers. The complete line represents a combination of many years of our research to send you qualified high fidelity components: Turntable Decks, Stereo Cartridges, Tone Arms, and Complete Players. The MICRO trademark, which symbolizes an elliptic stylus tracing the grooves, is tantamount to the slogan of the company, an integrated manufacturer specializing in the production of turntables that challenge the ultimate in faithful reproduction of the original sound. Each unit is assembled with craftsmanship skill and pride. Each completed unit is quality-tested at the factory and delivered to you to assure dependable and trouble free performance.



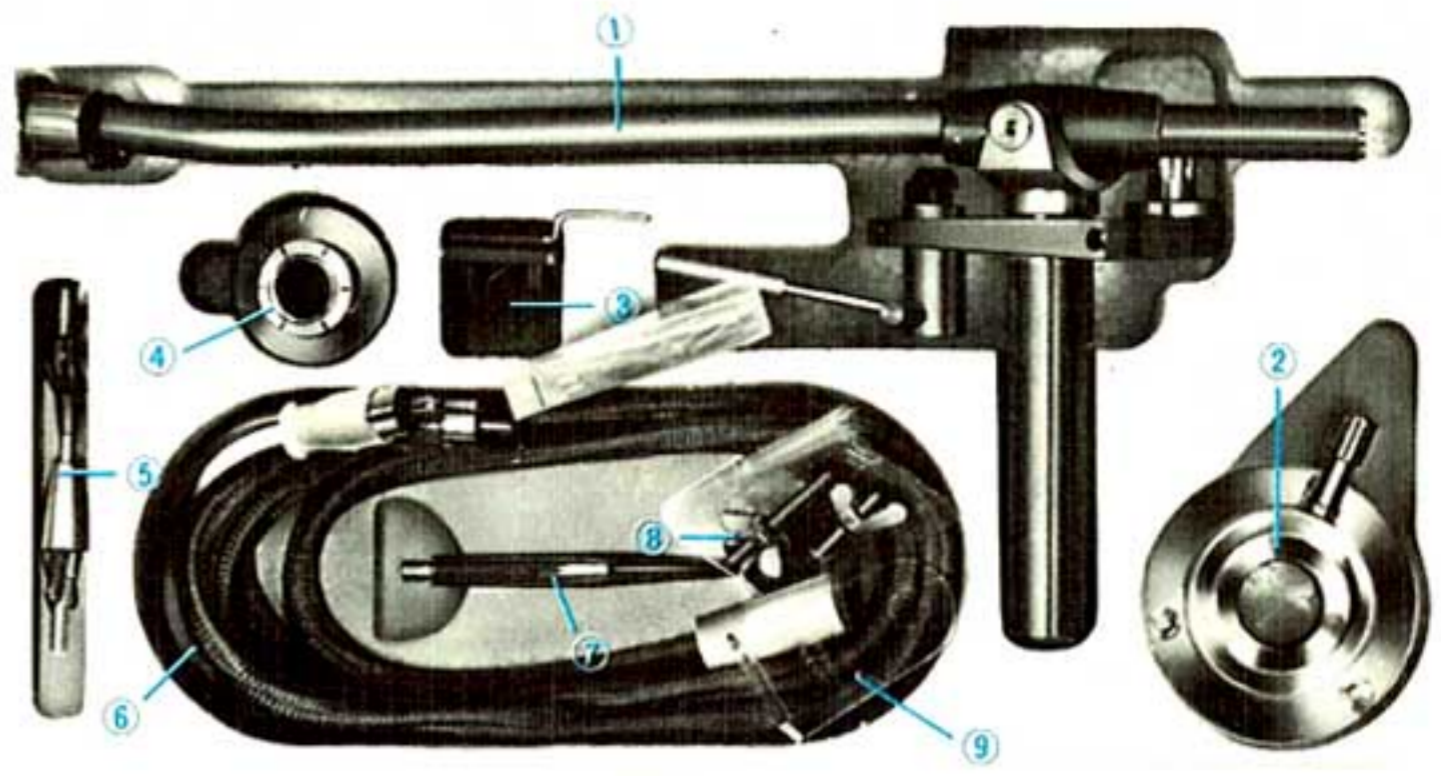
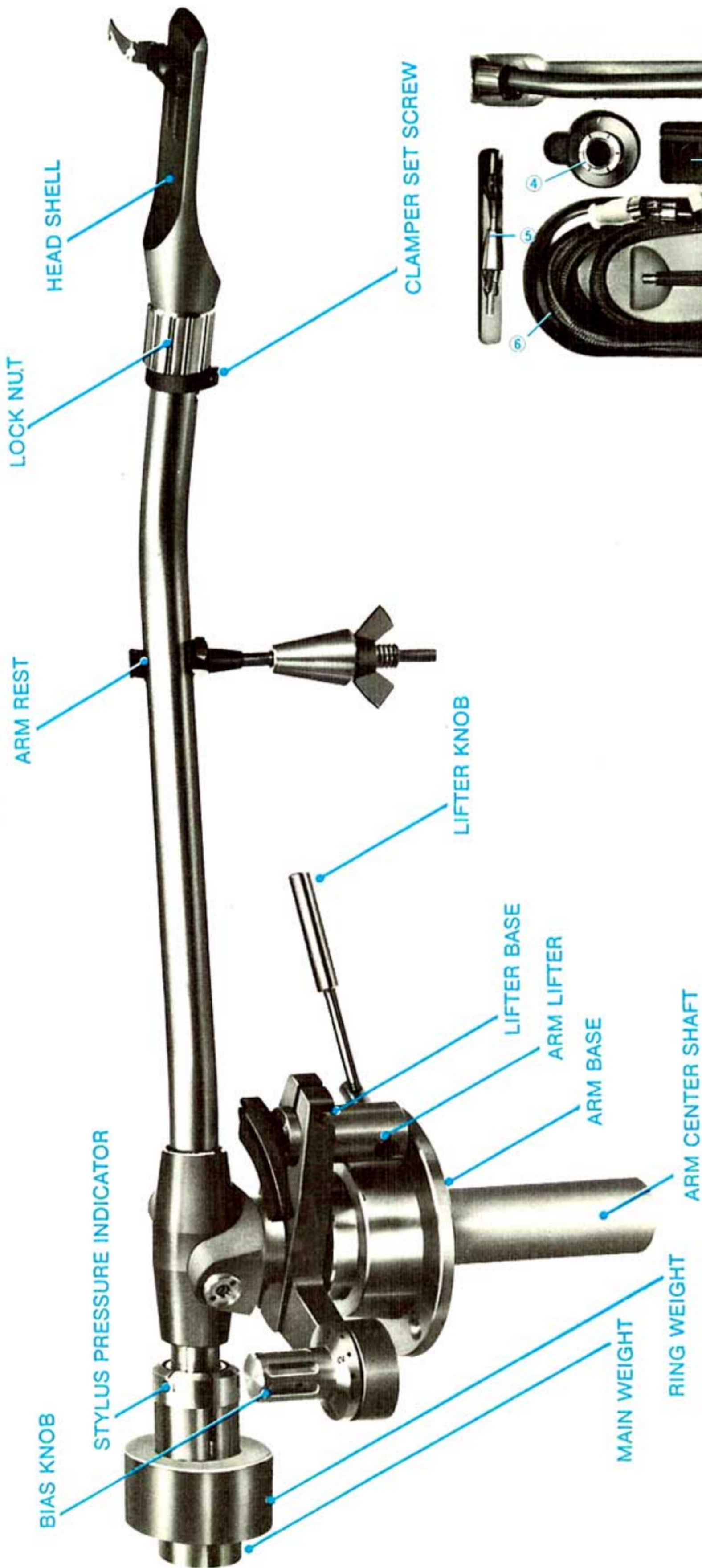

①

Identify the parts with Parts list and picture.

### HOW TO FIX TONE ARM

A player case on which the tonearm is fixed should be physically strong. Especially, a motor board is required to be more than 15mm in thickness and superb in surface planing.

- 1) When a turntable and a tonearm are mounted on the motor board at the same time, the fixing place of tonearm should be located by means of placing a fixing diagram (template) of tonearm on that of the turntable. In this case, care must be taken so that the operation of turntable and tonearm will be made smoothly, and the fixed tonearm can move anywhere on the record, while playing, without trouble. After the location of tonearm is decided, holes for the arm and arm rest will be bored, with diameters of 22mm for the former and 7mm for the latter. (See. 2).

**Note:** When a tonearm is fixed to the board on which a turntable has been already mounted, the tonearm template may be not exactly put on the motor board because of the level difference. Accordingly the location must be done carefully so as not to make a divergence of location. (See. 3).



2) The arm base should be tightly fixed to the motor board with attached wooden screws or metal screws, and the arm rest with flat V-shape nut. (See. 5).

**Note:** When the arm base is mounted, the height adjustment screw device must be located at the out side. (See. 4).



④



⑤

3) Pass an output cord through the arm base from its reverse side, and then insert it into the center shaft of arm, by making a projection of cord conform to a slot of the said center shaft. During this process, the said center shaft should be held by fingers so that no excessive force is given to the axis bearing of arm. Next, loosen the height adjustment screw of arm base with a screw driver, and insert arm shaft, and tighten the height adjustment screw so moderately that it does not drop in due to its self weight. And then put the arm on the arm rest. (See. 6).



⑥

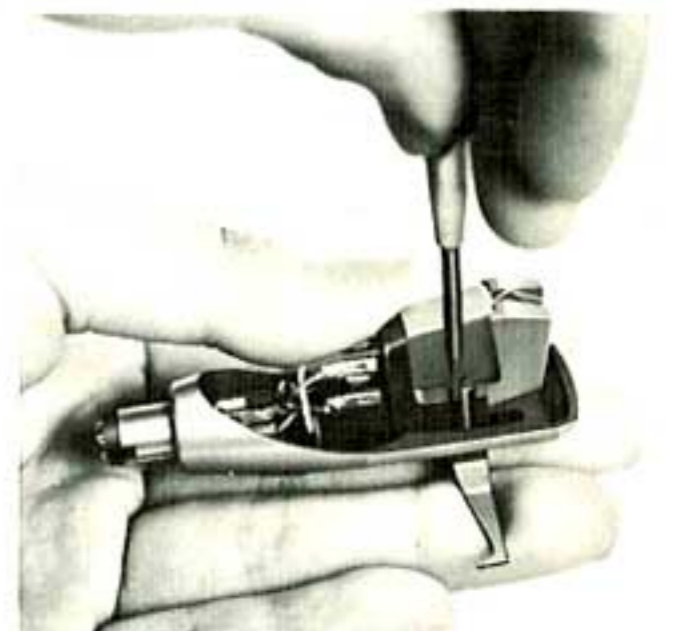

⑦



⑧



⑨

- ① MAIN BODY OF ARM
- ② ARM BASE
- ③ HEAD SHELL
- ④ WEIGHT
- ⑤ ARM REST
- ⑥ LOW-CAPACITY OUTPUT CORD
- ⑦ ATTACHED SCREW DRIVER
- ⑧ BASE FIXING SCREWS
- ⑨ SERVICING GAUGE

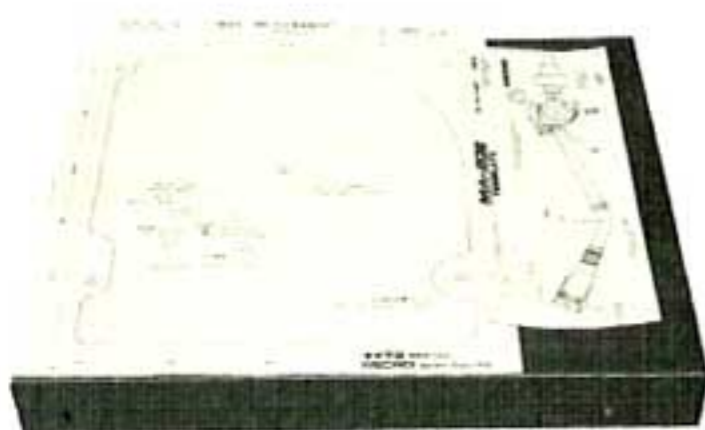

②

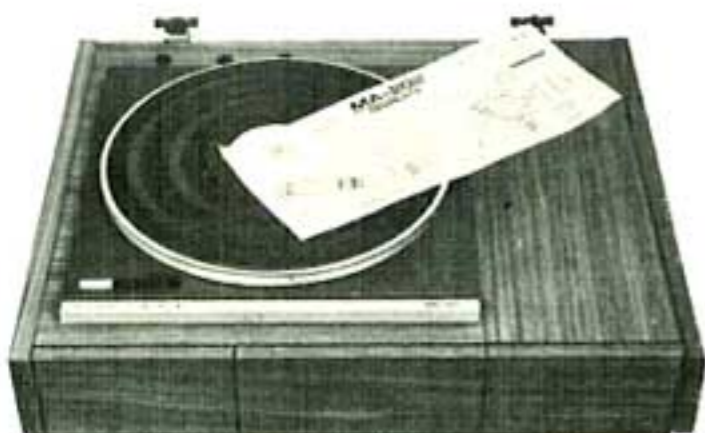

③

### HOW TO ASSEMBLE TONEARM

1) How to fix Cartridge and Head Shell

a. Picture 7

Fix a cartridge to a head shell by using provided screws or screws attached to the cartridge. In this case, center lines of head shell and cartridge should be on the same line.

b. Picture 8

Connect lead wires of head shell to the terminals of cartridge. The color coding of lead wires is:

Red R<sup>+</sup>, White L<sup>+</sup>, Green R<sup>-</sup> and Blue L<sup>-</sup> As the connections conform to the European Standard Specifications (EIA), the shell of EIA Specifications can be installed as it is.

c. Picture 9

After the cartridge is fixed, a head shell will be installed to the arm. In this case, in order to prevent the arm revolving part from unnecessary force, the head shell will be pushed in and locked carefully.



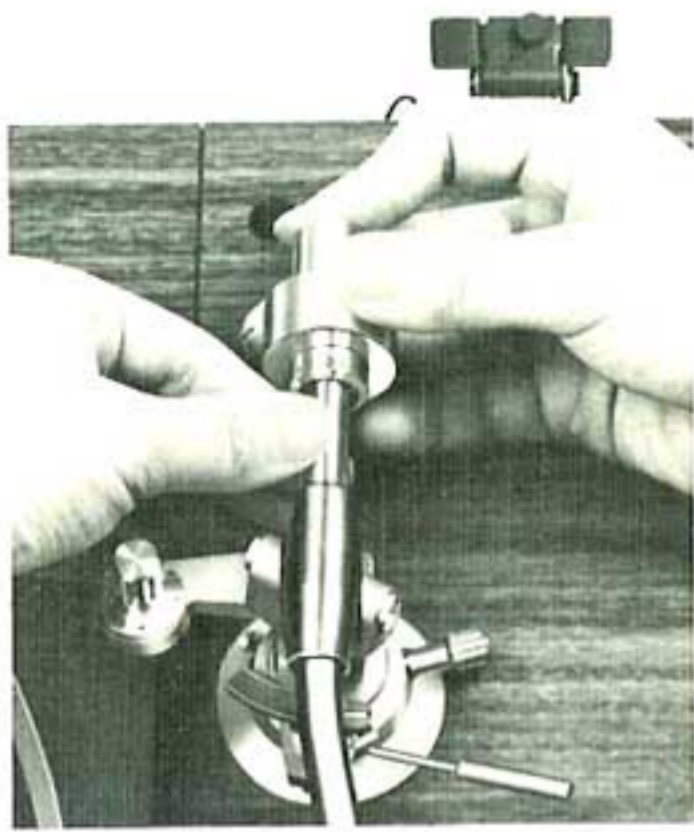

10

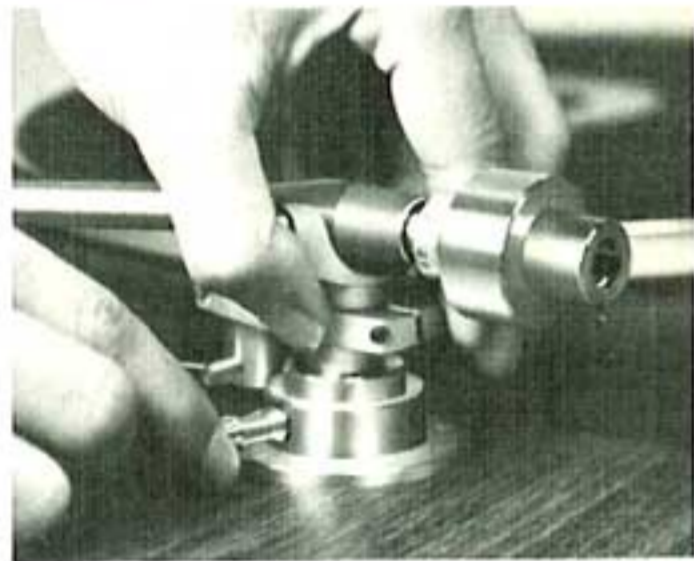

11

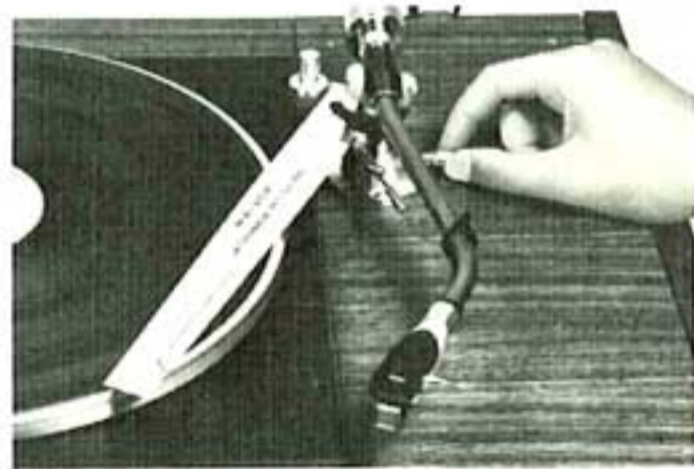

12

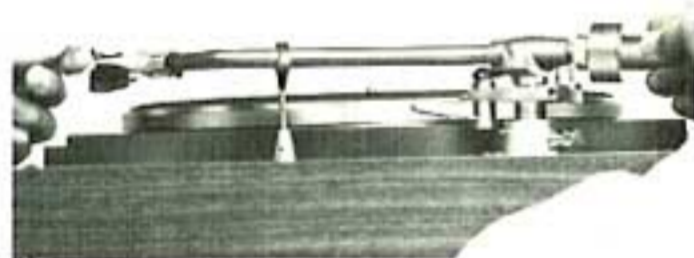

13

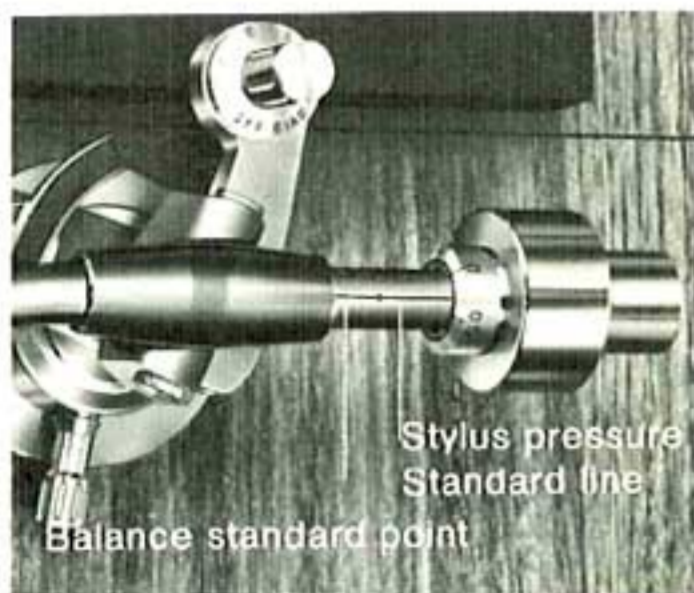

Stylus pressure  
Standard line  
Balance standard point

14

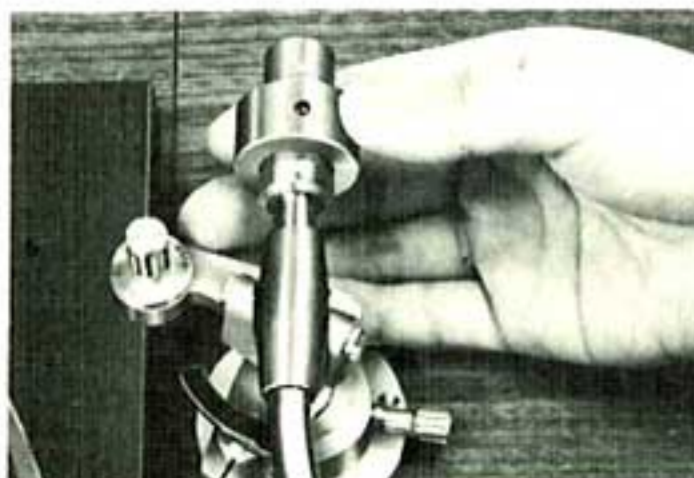

15

### 3) Adjustment of Stylus Pressure

When the arm is balanced horizontally, return it to the arm rest. Next, set a 0-scale of the stylus pressure indicator (a black part of main weight, with engraved figures) on the stylus pressure standard line by means of turning the said knob alone. Then turn counter-clockwise the entire main weight including the stylus pressure indicator and obtain the desired stylus pressure, reading the figure on scale. (Graduation unit of scaling is 0.5g, and 3g per turn.) (See. 16)

Note: In case of applying the stylus pressure, the stylus pressure can not be added unless the entire main weight is turned. Fix tightly a ring weight setting screw. When the horizontal balance is adjusted or the player is not used for long time, the bias knob scale is required to be set on "0" point.

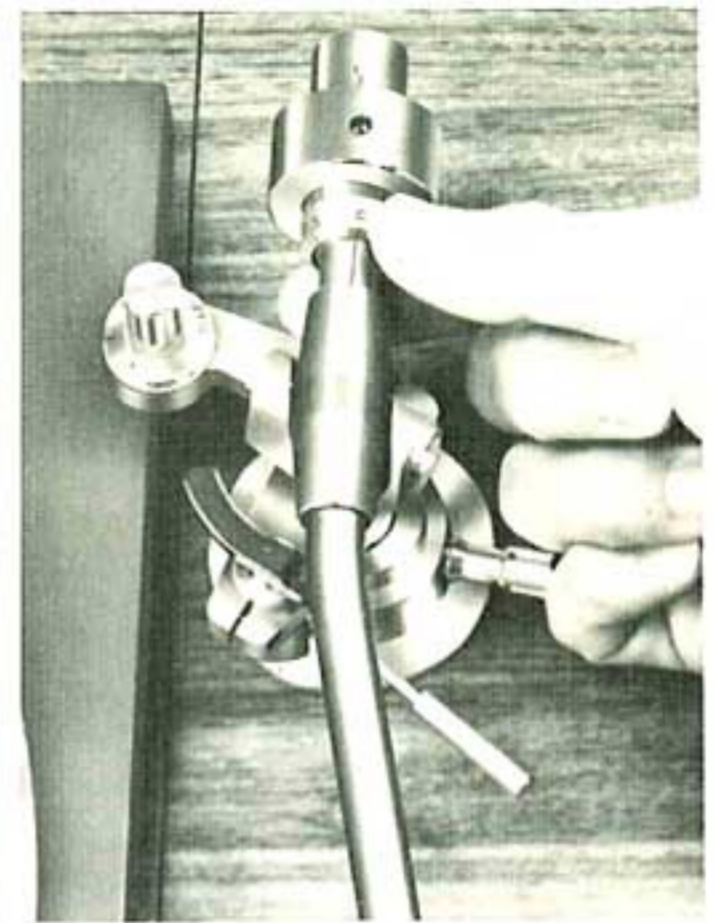

16

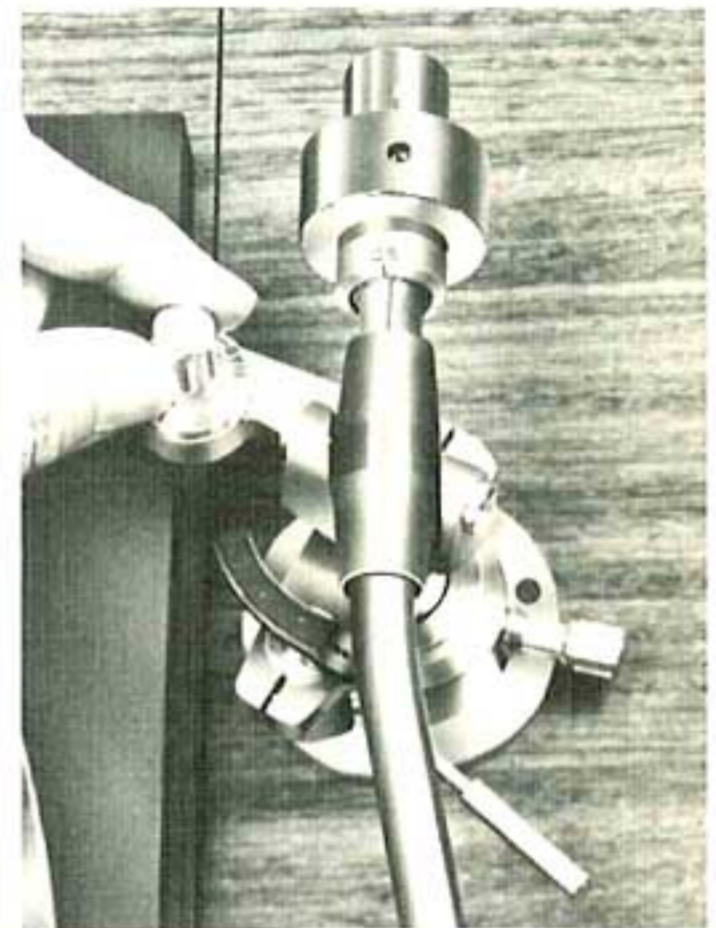

17

### 4) Adjustment of Anti-skating Device

Anti-skating device is a mechanism to cancel the inside force that a stylus is pulled towards the center of record due to revolutions of record during the playing. This force becomes stronger, according as a stylus nears the center of record. As a result, there will take place a difference of pressure between the right wall and left wall of a groove. The device that is designed to cancel this difference of force and give constantly the same stylus pressure to the both walls of a groove is the anti-skating device. The anti-skating device of this tonearm has the graduations corresponding to the stylus pressure scaling. So all that is necessary for balancing is to set the bias scale on 2 when the stylus pressure is 2g, and on 3 when it is 3g. In other words, it is required to set the bias scale on the corresponding figure of graduation. (See. 17)



Service gauge

18

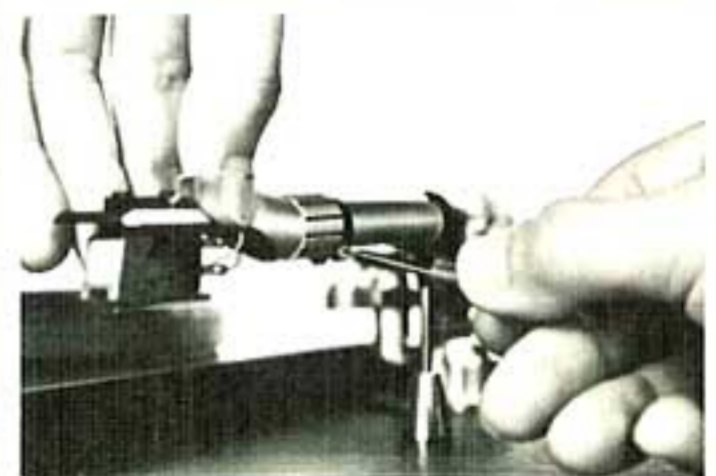

19

### 5) How to adjust Irregularly Fixed Head.

As seen in the picture 19, an adjustment screw is provided at a junction point (head lock) of head shell and arm. It is preset at the factory before the shipment, but it is loosened sometimes during the transportation or fixing works. In such a case or when other manufacturer's head shell is installed, the head is apt to be not in parallel with the record face. Such an irregularity has to be adjusted so as to keep the above-mentioned parallel, by loosening an adjustment screw and using a service gauge. (See. 18)

Note: It must be avoided to screw it tightly more than necessary.



normal

20



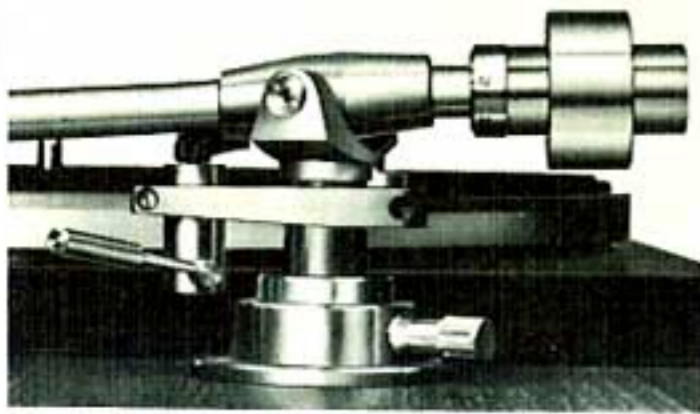

21



22



23

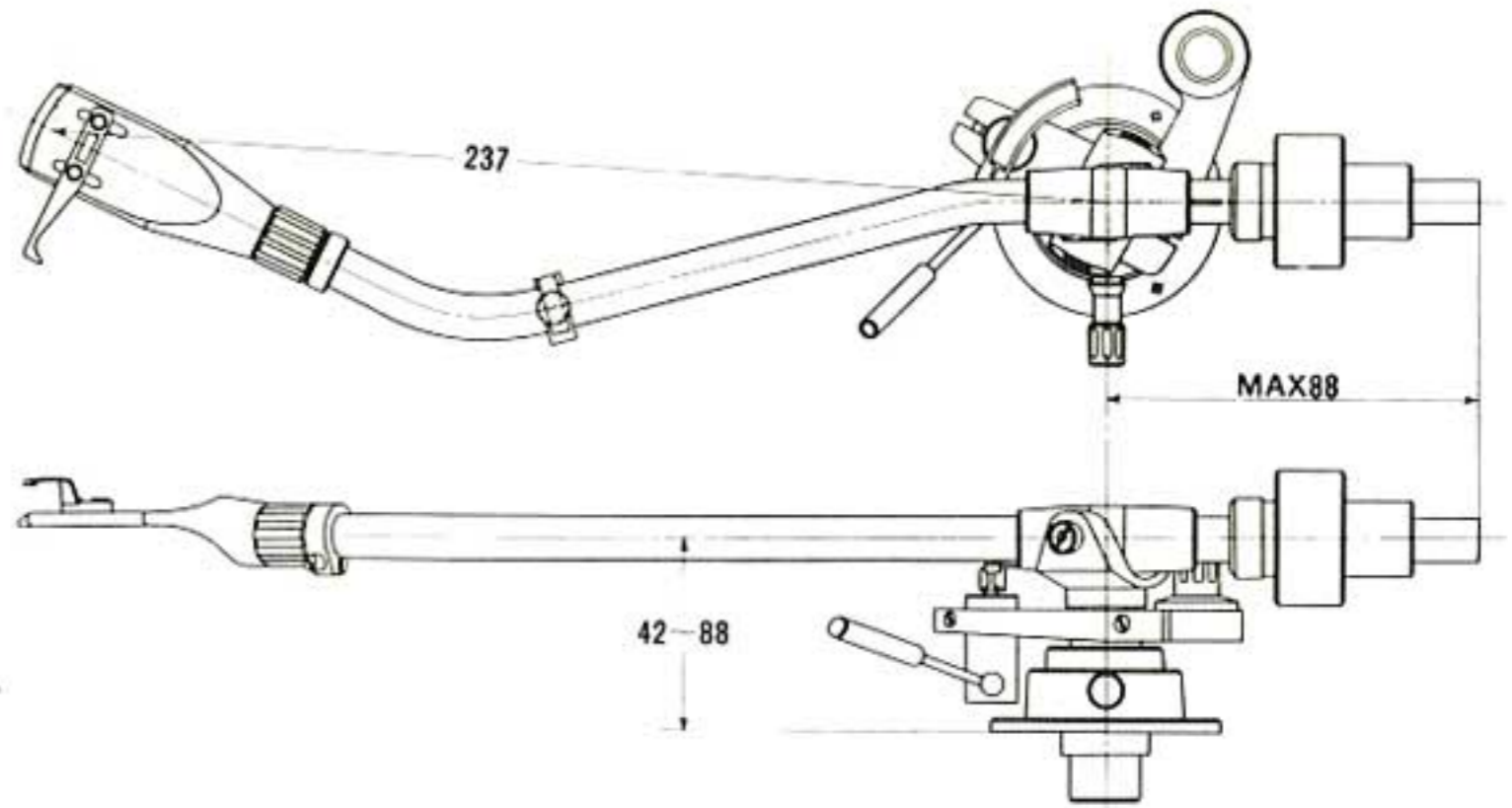

■ MA-202規格

**SPECIFICATIONS**

- Type:** Static balance universal type
- Length:** Overall 335mm (maximum)  
309 (minimum) Effective 237mm
- Overhang:** 15mm
- Offset angle:** 21°
- Tracking error angle:** less than 1.5°
- Adjustable range of height:** 42 ~ 88 mm (distance between motor board face and cartridge mounting face)
- Height adjustable range by lever manipulation:** Within 6mm
- Weight of matching cartridge:** 4 ~ 16g
- Stylus pressure variable range:** 0 ~ 3g direct reading (3g per turn)
- Anti-skating device:** Spring system
- Cancel force setting:** Stylus pressure corresponding (up to 400mg variable)
- Arm lifter:** Delay motion type with a shock absorber for arm lifting
- Head shell:** Provided with a head shell adjustment ring
- Output cord:** 5-p plug-in, low capacity (55 PF/m), shielded cord
- Head shell weight:** 9.7g
- Head connector:** SME type 4-p connector
- Connector:** Solid gold-plated

**MICRO**SEIKI CO., LTD.

19-19 FUJIMI-CHO ITABASHI-KU TOKYO JAPAN  
CABLE "MICROSEIKI" TOKYO · PHONE (962) 4621  
TELEX 0272-2427

PRINTED IN JAPAN