

RX-1500FVG OPERATION MANUAL

- 1 Remove the shipping screw on the underside of the air pump unit. Link the FV frame assembly, the motor unit and the air pump unit with the air tubes supplied, as shown in Fig.1.
- 2 Attach the carrying handles to the platter as shown in Fig.2. Holding these handles, carefully mount the platter to the FV frame assembly. Make sure that both the inside of the platter and the plate glass placed on the FV assembly are sufficiently clean. If they are not, clean them with the polishing cloth supplied.
- 3 Remove one handle from the platter and screw it into the center shaft. To enhance the contact between the platter and the center shaft taper.
- 4 Remove the two handles. Firmly set the center plate onto the center shaft with the hexagonal wrench supplied.

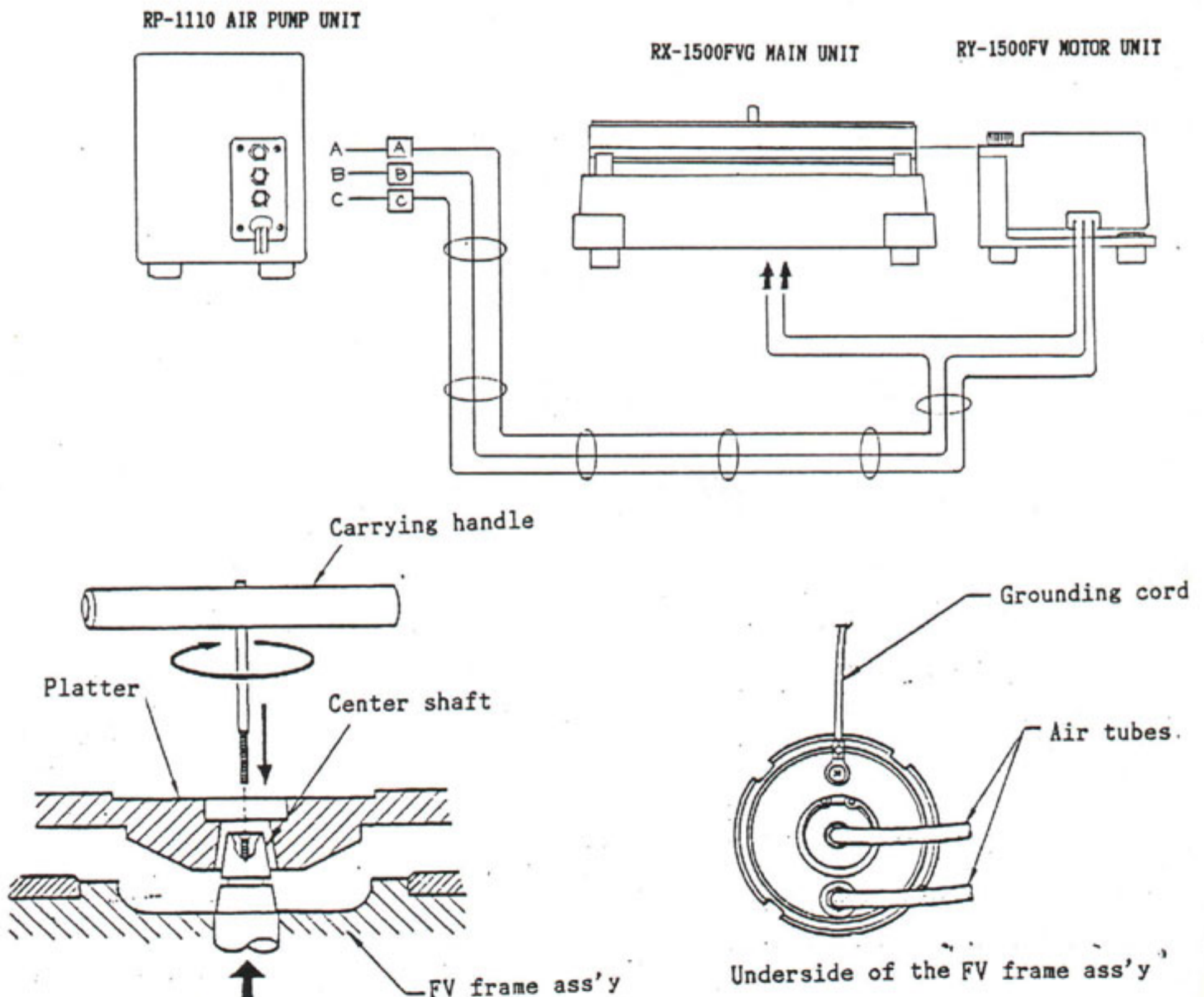

- 5 With the POWER switch on, the air pump unit goes into operation, and the platter floats up to $30\mu\text{m}$ high. Manually turn the platter and confirm that it can rotate smoothly with a light touch. In case it does not float completely, do not try to rotate it by force. This could result in damaging the plate glass.
- 6 Place the record on the platter. Confirm that the suction of the record is well achieved with the switching-on of the knob which is provided on the motor unit. Also confirm that the suction is released by the retro-jet of air with the switching off.
- 7 For further adjustment steps, refer to the operation manual of the Series 1500.

Fig.3 Assembling
of the RX-1500FVG

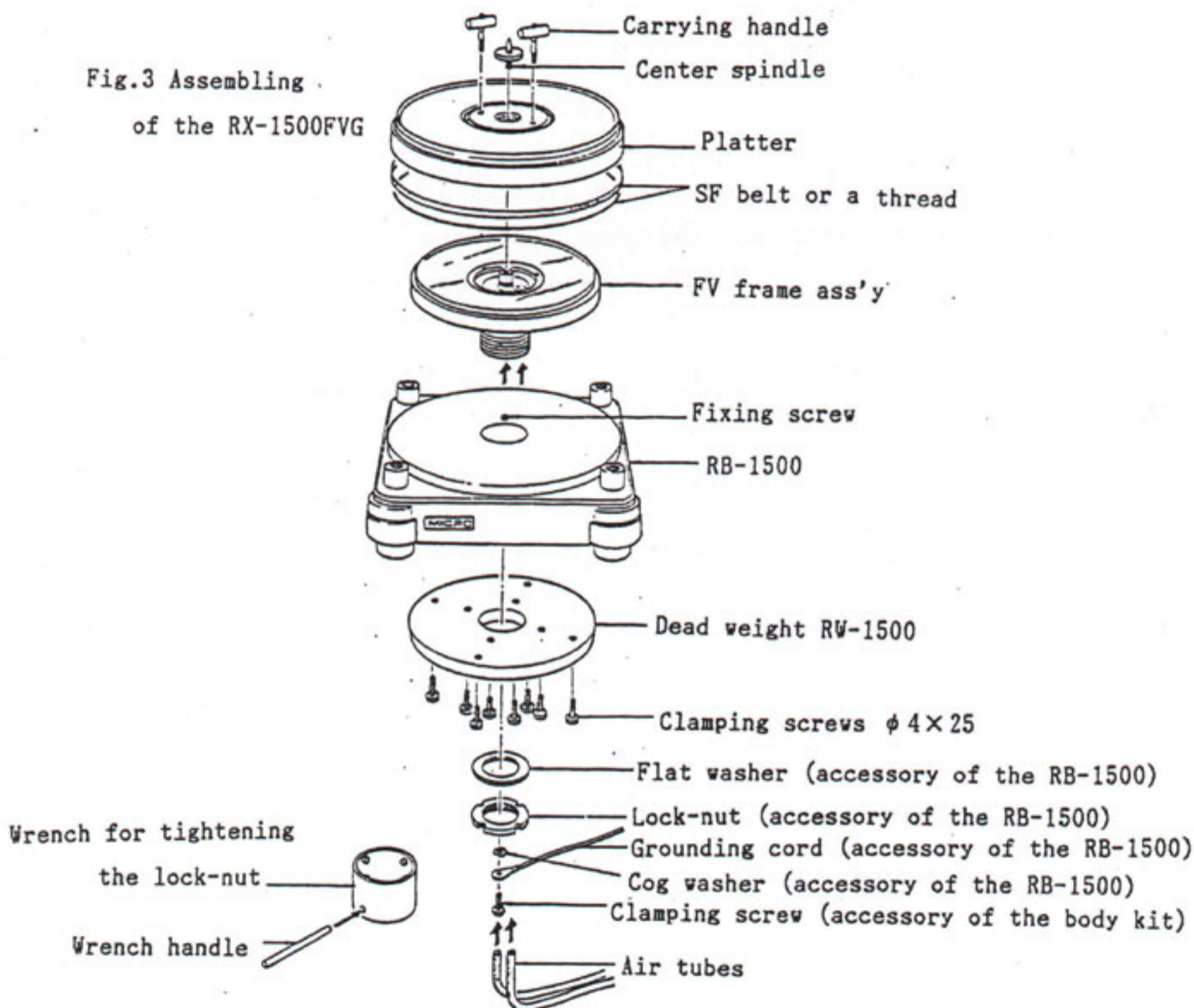

NOTICE

- Be sure to keep clean at all times the surface of the record and of the platter, especially when playing records. The rubber material on the platter should be cleaned at times with moistened tissue.
- The platter, which is made of cast bronze, should not be cleaned with tissue soaked in alcoholic substance. You have only to wipe it with dry or semi dry tissue.